

IK-HR1H

ULTRA SMALL HD 1080i/720p
CMOS REMOTE HEAD CAMERA

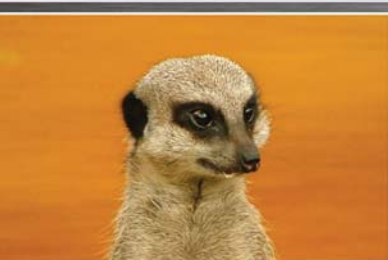
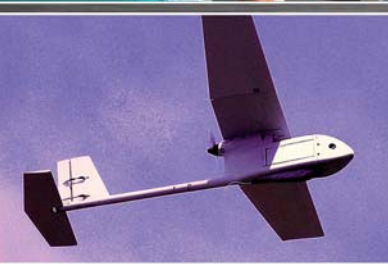

Features

- Ultra small (approx. 1.18" x 1.37" x 1.41")
- 1080i and 720p output selectable
- 1/3" progressive scan CMOS sensor
- DVI-I or HD-SDI output
- Weighs only 1.76 oz. (without lens)
- Auto and manual white balance
- Auto and manual electronic shutter
- Optional 3, 5, or 10 meter cables
- C-mount lens ready

Applications

- Life sciences / diagnostic imaging
- Surveillance / security
- Specialty broadcast / reality TV

Get Maximum Flexibility with our Tiniest High-Definition Remote Head Camera.

Toshiba's incredible IK-HR1H CMOS-based Color Camera System gives you power-packed HD performance in a tiny, lightweight package. Choose from two controller configurations for maximum flexibility and options. Let Toshiba bring your project to HD life.



TOSHIBA
Leading Innovation >>>

IK-HR1H CMOS Color Camera Head

Performance Specifications

	IK-HR1CD with IK-HR1H	IK-HR1CS with IK-HR1H
Power supply	12 VDC \pm 10% DCIN connector (4 pin)	12 VDC \pm 10% DCIN connector (4 pin)
Power consumption	Approx. 6.5W(TBD) at DC 12V	Approx. 5.8W (TBD) at DC 12V
Image sensor	1/3" progressive scan color CMOS Effective Pixels H:2000 V:1132	1/3" progressive scan color CMOS Effective Pixels H:2000 V:1132
Output pixels	Horizontal : 1920, Vertical : 1080i Horizontal : 1280, Vertical : 720p	Horizontal : 1920, Vertical : 1080i Horizontal : 1280, Vertical : 720p
Sync system	Internal	Internal
Video signal output	Digital output (DVI-I connector output) 8 bit X RGB Analog output (DVI-I connector output) R : 0.7Vp-p \pm 10% (75 ohm unbalanced) G : 0.7Vp-p \pm 10% (75 ohm unbalanced) B : 0.7Vp-p \pm 10% (75 ohm unbalanced)	SDI: (Serial Digital Interface) (BNC connector) Based upon SMPTE 292M
Sensitivity	F4 Standard (at 2000lx, 3000K, 1/60s)	F4 Standard (at 2000lx, 3000K, 1/60s)
Minimum illumination	31 lx (F1.4, Gain 18dB)	8lx (50IRE, F1.0, Gain 18dB, Gamma = OFF)
Dimension & Weight	IK-HR1H (HEAD) W: 30, H: 35, D: 36 (mm) Approx 50g IK-HR1CD (CCU) W: 44, H: 44, D: 77.5 (mm) Approx 146g	IK-HR1H (HEAD) W: 30, H: 35, D: 36 (mm) Approx 50g IK-HR1CD (CCU) W: 44, H: 44, D: 77.5 (mm) Approx 146g
Operating temperature	0° ~ +40°C (32° F ~ 140° F)	0° ~ +40°C (32° F ~ 140° F)
Storage temperature	-20°C ~ +60°C (-4° F ~ 140° F)	-20°C ~ +60°C (-4° F ~ 140° F)

Feature Specifications

	IK-HR1CD with IK-HR1H	IK-HR1CS with IK-HR1H
Shutter	AUTO / MANUAL / SS (Synchro Scan) AUTO : Peak / Average / Response speed / Area MANUAL : OFF, 1/100s, 1/125s, 1/250s, 1/500s, 1/1000s, 1/2000s, 1/4000s, 1/8000s, 1/16000s, 1/32000s, SS (Synchro Scan) : 2/1125H ~ 1123/1125H	AUTO / MANUAL / SS (Synchro Scan) AUTO : Peak / Average / Response speed / Area MANUAL : OFF, 1/100s, 1/125s, 1/250s, 1/500s, 1/1000s, 1/2000s, 1/4000s SS (Synchro Scan) : [1080i mode] OFF, 2/1125H ~ 1123/1125H [720p mode] OFF, 2/750H ~ 748/750H
Gamma	OFF / ON : -10 ~ 0 ~ 10 step control	OFF / ON : -10 ~ 0 ~ 10 step control
Gain Control	OFF / ON : 0 ~ 12dB 1dB step	OFF / ON : 0 ~ 12dB 1dB step
White Balance	AWB / ATW / MANUAL AWB :3200 K/5600 K ATW :3000 ~ 6000 K MANUAL:R,B level adjustment 3200 K/5600 K	AWB / ATW / MANUAL AWB :3200 K/5600 K ATW :3000 ~ 6000 K MANUAL:R,B level adjustment 3200 K/5600 K
Scene file setting	5 files A/B/C/D/E	5 files A/B/C/D/E
Remote control	RS-232C protocol: Baud rate 9600bps/19200bps (Rx,D, Tx,D, GND)	RS-232C protocol: Baud rate 9600bps/19200bps (Rx,D, Tx,D, GND)

Design and specifications are subject to change without notice.

Connection

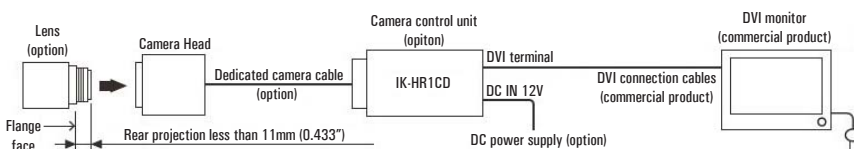

© 2009 Toshiba America Information Systems, Inc. All rights reserved. All products and names mentioned are the property of their respective owners. While Toshiba has made every effort at the time of publication to ensure the accuracy of the information provided herein, product specifications, configurations, prices, system/component/options availability are all subject to change without notice.

IK-HR1CD CCU

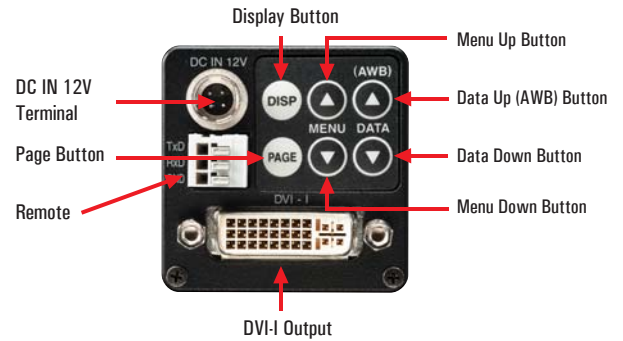

IK-HR1CS CCU

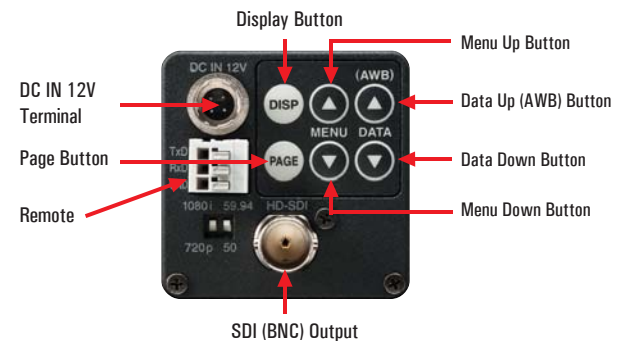

Exterior Dimensions

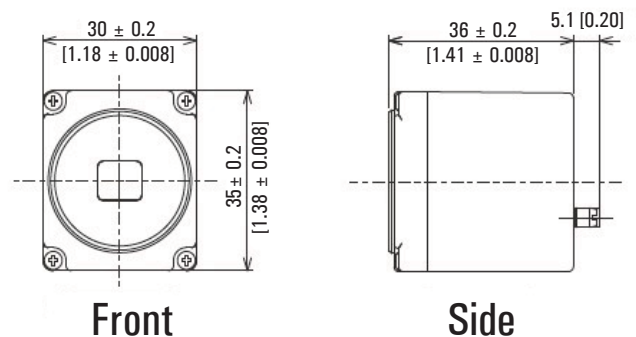

System Components

For further details, contact your Toshiba ME/FA distributor.

Camera System

IK-HR1H	Camera Head
---------	-------------

Camera Cable

Model	Length
EXC-HR03	3 m
EXC-HR05	5 m
EXC-HR10	10 m

Camera Control Units

IK-HD1CS	HD-SDI @ 60 Hz Output
IK-HD1CD	DVI @ 60Hz Output

TOSHIBA

Leading Innovation >>>

Toshiba America Information Systems, Inc.
Imaging Systems Division
9740 Irvine Boulevard, Irvine, California 92618
949-583-3320 • www.cameras.toshiba.com